



EARTH DRILL SERIES 3



SUITABLE FOR 2 - 5 TONNE MINI EXCAVATORS, SKIDSTEERS & TRUCK CRANES

The Series 3 Earth Drill range is the perfect choice for 1-5T mini excavators, mini loaders, skidsteers, backhoes and truck cranes. And, just like all planetary drives in our line up they are highly engineered and built to last.

HIGH QUALITY HYDRAULIC MOTORS

Auger Torque's huge buying power means we work closely with high quality suppliers to develop the most reliable attachments available on the market today.

EPICYCLIC GEARBOX

Torque is amplified by using the unique Auger Torque planetary gearbox. This system allows the motors output torque to be multiplied with extreme efficiency as well as ensuring the durability and reliability you need.

FORGED HOOD EARS

Standard with all Earth Drills in areas that we know will take a lot of strain. All hood pins are locked for extra safety making it impossible for the hood to detach from your hitch.

NON-DISLODGE MENT SHAFT

Unique to Auger Torque, the Non-Dislodgement Shaft is a single piece drive shaft assembled top down and locked into the Earth Drill housing. This design guarantees that the shaft will never fall out, making for a safer work environment, not only for the operator but also any surrounding workers, a **MUST-HAVE FEATURE** for any safety conscious company.



Visit the Auger Torque website to watch a demo

www.augertorqueusa.com

CALL +1 844 287 6300

EMAIL sales@augertorqueusa.com

OR CONTACT YOUR NEAREST DEALER

EARTH DRILL – SERIES 3

Features

- ▶ Unique Auger Torque planetary gearbox offering high efficiency and extreme durability
- ▶ Single piece drive shaft
- ▶ Large main shaft bearings
- ▶ Heavy duty steel construction
- ▶ Compatible with Auger Torques range of Alignment and Torque Monitoring products for **accurate earth drilling applications**
- ▶ Covered by Auger Torque's industry leading warranty

Applications

- ▶ Pre-augering
- ▶ Pole and mast installations
- ▶ Rail applications
- ▶ Deep hole applications
- ▶ Well boring

Specifications

Model		2200-20	2700-25	3300-30	2300-10
Carrier Weight					
Excavator		2-4t	2.5-4.5t	3-5t	-
Skidsteer		50hp	65hp	80hp	-
Truck Crane		-	-	-	9t/m
Torque Range	ft-lb	707-2122	888-2665	1106-3318	707-2298
Oil Pressure Range	psi	1160-3481	1160-3481	1160-3481	1160-3771
Oil Flow Range	gpm	7-20	10-25	13-30	1.5-10
Speed Range	rpm	36-100	42-90	40-77	7-46
Unit Height	inch	26	26	26	26
Unit Diameter	inch	10	10	10	10
Unit Weight	lb	157	161	166	161
Output Shaft Std (adaptors available)	inch	2 Hex	2 Hex	2 Hex	2 Hex

Drilling Performance

Auger Series		S4	S4	S4	S4
Auger Diameter	inch	4-24	4-30	4-36	4-24
Drilling Depth*	ft	10-5	10-5	13-4	10-4

*Dependent on ground type

HITCH OPTIONS

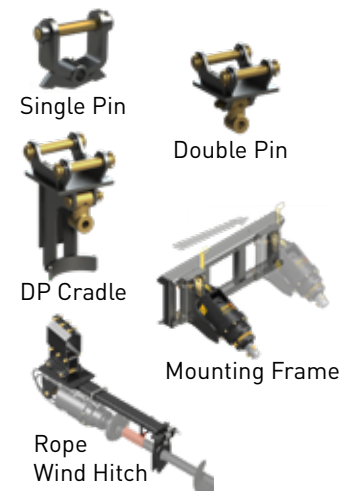

EXTRAS (model dependent)



Part of the Auger Torque Earthmoving range

EARTH DRILLS | AUGERS & WEAR PARTS | MULCHERS | TRENCHERS | HAMMERS

www.augertorqueusa.com

CALL +1 844 287 6300

EMAIL sales@augertorqueusa.com

OR CONTACT YOUR NEAREST DEALER