



VARIABLE MULCHER



RELIABLE & VERSATILE, WHATEVER THE JOB

Suitable for excavators and skid steer loaders, these mulchers are designed and manufactured to handle the toughest clearance applications through to precise hedge trimming.

What really makes this mulcher unique is the option of different drums, so whatever the job at hand you can easily switch between the options, providing the ultimate solution for all your land clearing needs.

HEAVY DUTY CONSTRUCTION

- ▶ Solid steel structure
- ▶ Low profile design for good visibility
- ▶ Removable side plates for easy belt access
- ▶ Drainage holes for use in bad weather

HINGED DOOR

- ▶ Adjustable for optimised performance
- ▶ Easy access for maintenance checks
- ▶ Heavy duty hinges & dual locking pins

HEAVY DUTY BEARINGS & TRIPLE BELT SYSTEM

- ▶ Large bearings for smooth running & reliability
- ▶ Shrouded external greasing points
- ▶ Easy access triple belt system

REMOVEABLE PUSH BAR & PRESSURE GAUGE

Easily convert from skid steer to excavator operation - remove the push bar & pressure gauge to help save on weight & bulkiness when attached to excavators.

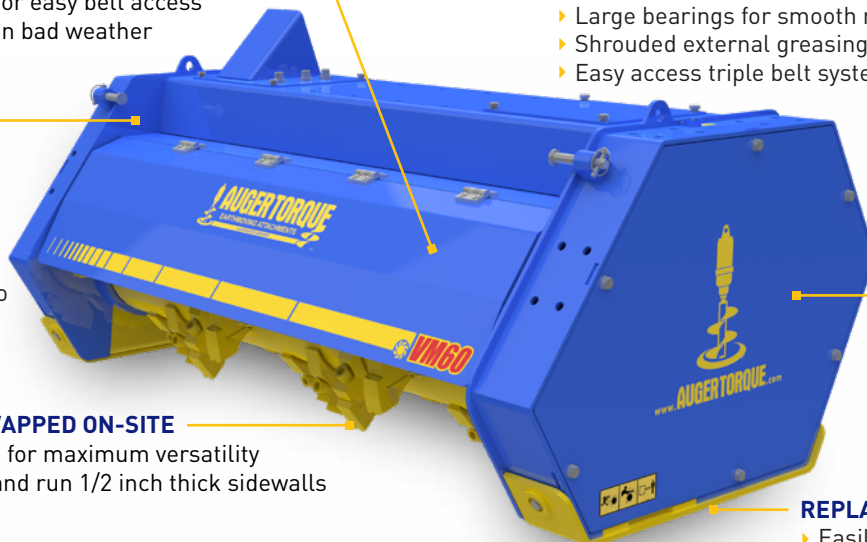

HEAVY DUTY DRUM - EASILY SWAPPED ON-SITE

- ▶ Drum change on-site with ease for maximum versatility
- ▶ Drums balanced to grade G16 and run 1/2 inch thick sidewalls

OPTIMISED CUTTING TEETH

- ▶ Designed for optimal strike rate & timing to prevent drum stall & clogging



FIXED TUNGSTEN TOOTH DRUM

- ▶ The toughest and most versatile option.
- ▶ Suitable for solid timber up to 10 inch thick, lighter material like hedges and tree branches.

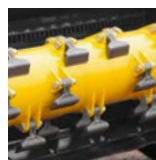

SWINGING HAMMER TOOTH DRUM

- ▶ Offers a cleaner cutting performance on soft materials.
- ▶ Ideal for lighter work where clean cutting of soft vegetation is required like reshaping dense hedgerows or processing hedge and branch trimmings into mulch.
- ▶ Capable of mulching smaller trees down to ground.

REPLACEABLE SKID PLATES

- ▶ Easily removed & replaced
- ▶ Also aids drum storage

www.augertorqueusa.com

CALL +1 770 741 0180

EMAIL sales@augertorqueusa.com

OR CONTACT YOUR NEAREST DEALER

APPLICATIONS

- ▶ Ground clearance
- ▶ Woodland pathway creation and maintenance
- ▶ Clear and maintain vegetation
- ▶ Processing tree and hedge trimmings
- ▶ Mulch trees and hedges down to ground level
- ▶ Fire break creation
- ▶ Compost mulching
- ▶ Hedge maintenance
- ▶ VM40 suitable for solid timber up to 10 inch (250 mm)
- ▶ VM60 suitable for solid timber up to 5 inch (125 mm)
- ▶ Mowing grass and dense bushes
- ▶ Maintenance of roadside vegetation
- ▶ Orchard & vineyard maintenance

SPECIFICATIONS

VM40

Standard Gear Motor

Oil Pressure Range: 2320.6 - 2610.7 psi (160 - 180 BAR)

Optimum Oil Pressure: 2610.7 psi (180 BAR)

Oil Flow Range: 15.85 - 18.49 gpm (60 - 70 LPM)

Optimum Oil Flow: 18.49 gpm (70 LPM)

SUITABLE FOR EXCAVATORS

5T to 10T

SKIDSTEER COMPATIBLE

Suitable for machines that can obtain the above pressures and flow rates

CUTTING

Drum Speed: up to 2400rpm (parent machine dependant)

Cutting drum width: 40 in (1000mm)

Swinging drum: Cuts up to 3 in (75 mm) diameter

Fixed drum: Cuts up to 5 in (125 mm) diameter

DIMENSIONS

27.32in x 49.61in x 31.57in (h x w x d)

694mm x 1260mm x 802mm (h x w x d)

WEIGHT

882 lbs (400 kg)

VM60

Standard Piston Motor

Oil Pressure Range: 3190.8 - 3480.9 psi (220- 240 BAR)

Optimum Oil Pressure: 3480.9 psi (240 BAR)

Oil Flow Range: 85 - 22.4 - 25.0 gpm (95 LPM)

Optimum Oil Flow: 25.0 gpm (95 LPM)

SUITABLE FOR EXCAVATORS

10T to 15T

SKIDSTEER COMPATIBLE

Suitable for machines that can obtain the above pressures and flow rates

CUTTING

Drum Speed: up to 2400rpm (parent machine dependant)

Cutting drum width: 60 in (1500mm)

Swinging drum: Cuts up to 5 in (125 mm) diameter

Fixed drum: Cuts up to 10 in (250 mm diameter)

DIMENSIONS

34.06in x 72.05in x 39.45in (h x w x d)

865mm x 1830mm x 1002mm (h x w x d)

WEIGHT

1763.7 lbs (800 kg)



Part of the Auger Torque Landscaping Range

STUMP PLANERS | LOG SPLITTERS | MULCHERS | HEDGE TRIMMERS | SWEEPER BROOMS

www.augertorqueusa.com

CALL +1 770 741 0180

EMAIL sales@augertorqueusa.com

OR CONTACT YOUR NEAREST DEALER